

REVISIONS					
LTR	ECO	DESCRIPTION	DATE	APPROVED	ZONE
A		INITIAL_RELEASE	4/8/2016	RWW	

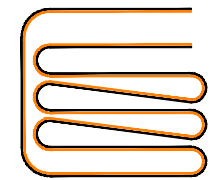

PIECE 1

← UNFOLD

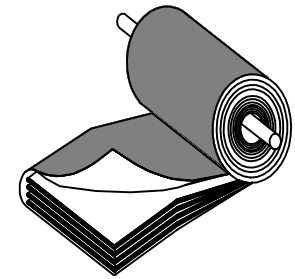
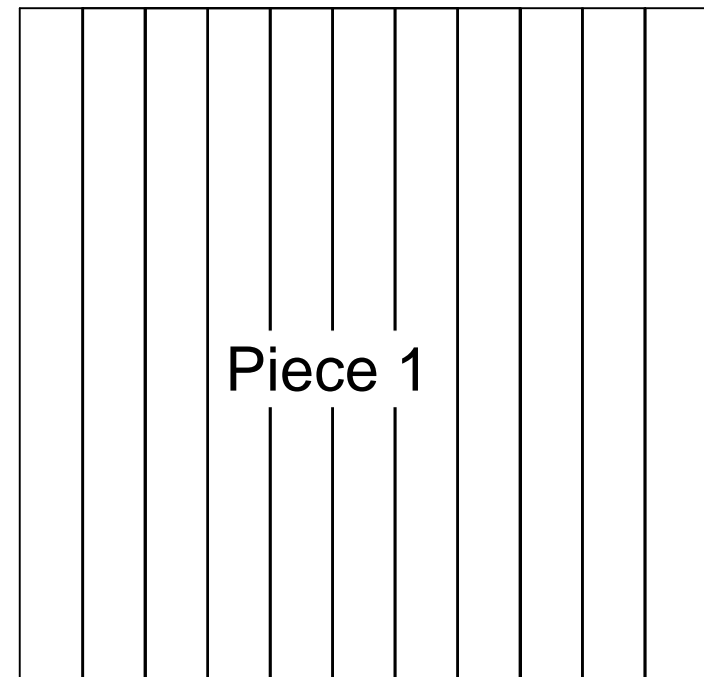

Piece 1

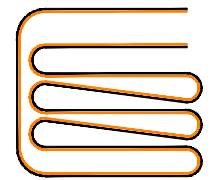
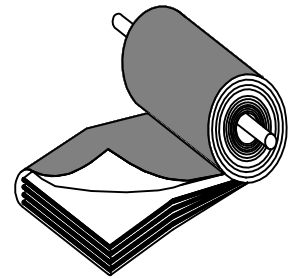

PIECE 2

UNFOLD →

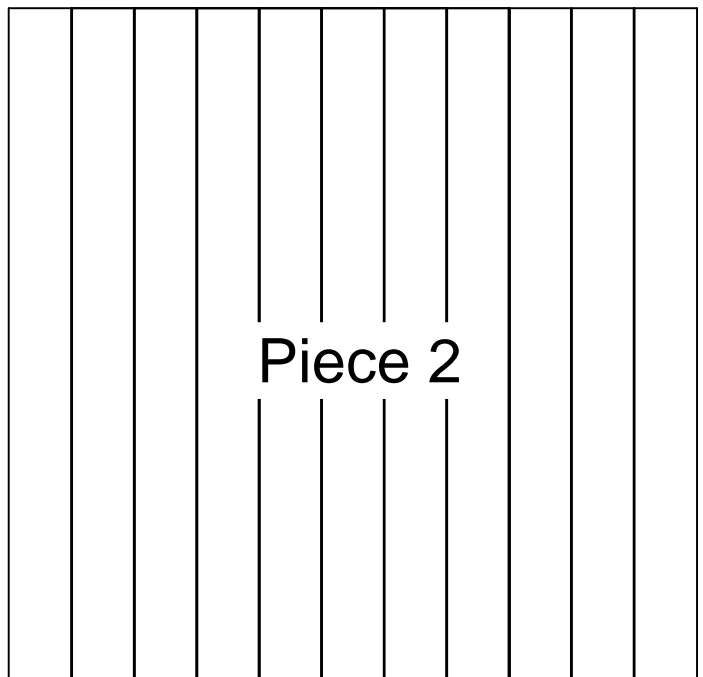

Piece 2

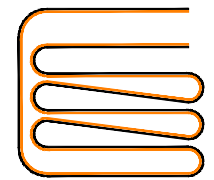
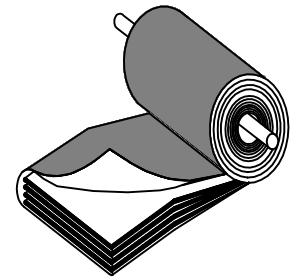

PIECE 3

UNFOLD →

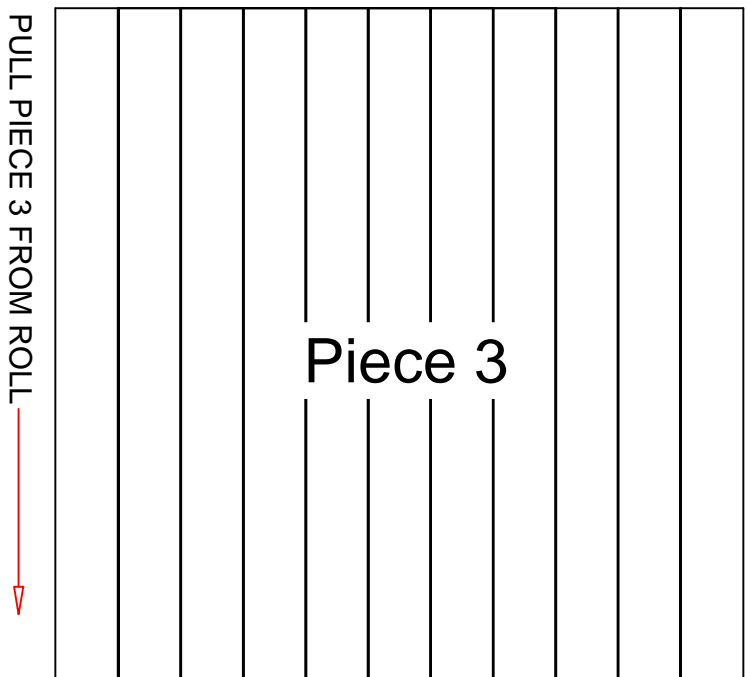

Piece 3

BUNKER STARTING END

BUNKER FINISHING END

**DEPLOYMENT INSTRUCTIONS;**

1. DETERMINE IF THE FIRST PANEL IS FLIP FOLDED. THIS CAN BE DONE BY LOOKING AT THE COLOR OF THE MATERIAL AS IT IS BEING UNROLLED. IF THE MATERIAL IS BLACK ON BOTH SIDES OF THE ROLL IT IS FLIP FOLDED. THIS INSTRUCTION IS FOR A FLIP FOLDED ROLL. IF THE ROLL IS WHITE ON THE TOP OF THE UNROLL YOU WILL NEED TO USE THE INSTRUCTIONS FOR ACCORDION FOLDED.
2. PULL PIECE 1 & 2 ACROSS THE GRAIN PILE ABOUT 1/3 OF THE WAY FROM THE STARTING END
3. PULL TOP LAYER OF PIECE 1 OFF AND PULL TOWARDS THE STARTING END OF THE BUNKER
4. JOIN TOP LAYER OF PIECE 1 TO TOP PANEL OF PIECE 2 AS SHOWN ON NEXT PAGE
5. FLIP REMAINING ACCORDION FOLDED PANELS OF PIECE 1 OVER PIECE 2
6. WHILE HOLDING PIECE 2 PULL PIECE 1 TO THE STARTING END OF THE BUNKER
7. UNFOLD PIECE 2
8. UNROLL PIECE 3
9. SEW SEAM OF PIECE 2 AND 3 AS SHOWN IS STEPS 3 & 4 ABOVE
10. UNFOLD PIECE 3 TO THE FINISHING END OF THE BUNKER

		COVER TYPE			
		3 PIECE RECTANGULAR Flip Folded, Page 1 of 3			
RAVEN ENGINEERED FILMS PO BOX 5107 SIOUX FALLS, SD 57117-5107 +1 (800) 635-3456		SIZE	SALES ORDER	TYPE OF DRAWING	REV
DRAWN	RWW	DATE	4/8/2016	B	1 O3NOFS A
DO NOT SCALE DRAWING		PROPRIETARY AND CONFIDENTIAL INFORMATION OF RAVEN INDUSTRIES INC. THIS DRAWING AND THE INFORMATION HEREON ARE RAVEN INDUSTRIES INC. PROPERTY AND MAY BE USED BY OTHERS ONLY AS AUTHORIZED IN WRITING BY RAVEN INDUSTRIES INC. - ALL RIGHTS RESERVED UNDER THE COPYRIGHT LAWS.			

REVISIONS					
LTR	ECO	DESCRIPTION	DATE	APPROVED	ZONE
A		INITIAL_RELEASE	4/8/2016	RWW	

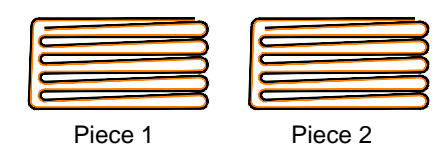

FIGURE 1

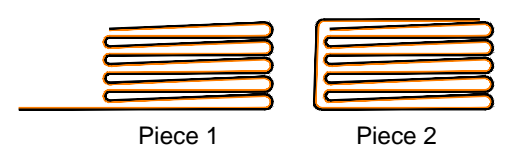

FIGURE 2

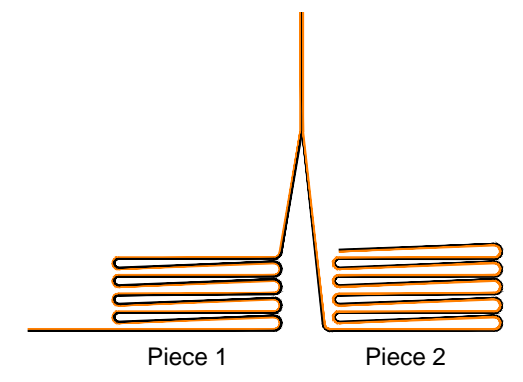

FIGURE 3

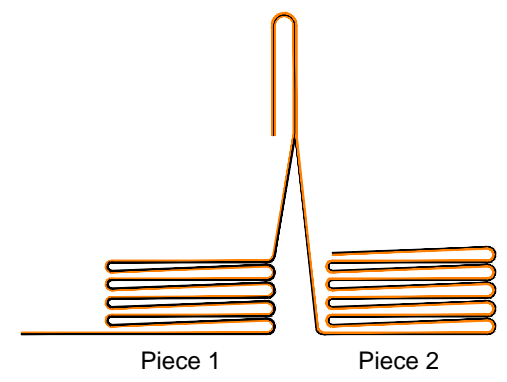

FIGURE 4

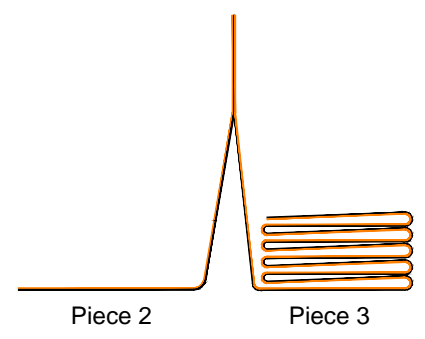

FIGURE 5

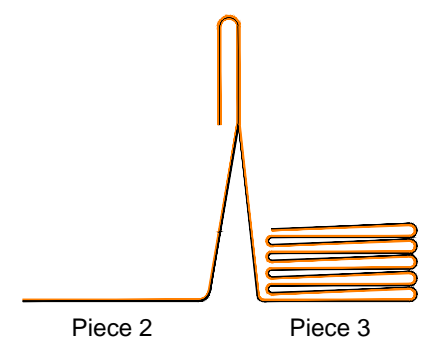

FIGURE 6

**SEWING INSTRUCTIONS**

1. ONCE FIRST AND SECOND PANEL ARE UNROLLED, FLIP THE TOP FOLD OF PIECE1 TOWARDS THE BUNKER STARTING END, (FIGURE 2)
2. LIFT UP THE NEXT PANEL OF PIECE 1 AND THE TOP PANEL OF PIECE 2 HOLDING THE PANELS TOGETHER BLACK TO BLACK, (FIGURE 3)
3. SEW ACROSS THE ENTIRE SEAM AS SHOWN IN THE GENERAL SEWING INSTRUCTIONS, (PAGE 5)
4. FOLD OVER EXISTING SEWN SEAM AND SEW A SECOND PASS AS SHOWN ON THE GENERAL SEWING INSTRUCTIONS, (FIGURE 4)
5. ONCE PIECE 3 IS UNROLLED LIFT END OF PIECE 2 AND SEW BLACK TO BLACK, (FIGURE 5)
6. FOLD OVER EXISTING SEWN SEAM AND SEW A SECOND PASS AS SHOWN ON THE GENERAL SEWING INSTRUCTIONS, (FIGURE 6)

	COVER TYPE		
	3 PIECE RECTANGULAR Flip Folded, Page 2 of 3		
RAVEN ENGINEERED FILMS PO BOX 5107 SIOUX FALLS, SD 57117-5107 +1 (800) 635-3456	SIZE	SALES ORDER	TYPE OF DRAWING
NAME: RWW DATE: 4/8/2016	B	1	O3NOFS-2
DRAWN: RWW	PROPRIETARY AND CONFIDENTIAL INFORMATION OF RAVEN INDUSTRIES INC.		REV: A
DO NOT SCALE DRAWING	THIS DRAWING AND THE INFORMATION HEREON ARE RAVEN INDUSTRIES INC. PROPERTY AND MAY BE USED BY OTHERS ONLY AS AUTHORIZED IN WRITING BY RAVEN INDUSTRIES INC. - ALL RIGHTS RESERVED UNDER THE COPYRIGHT LAWS.		

8

7

6

5

4

3

2

1

REVISIONS					
LTR	ECO	DESCRIPTION	DATE	APPROVED	ZONE
A		INITIAL_RELEASE	1/18/2016	RWW	
B		REV_TITLE_BLOCK	3/28/2016	RWW	

NOTES:

XXXXX

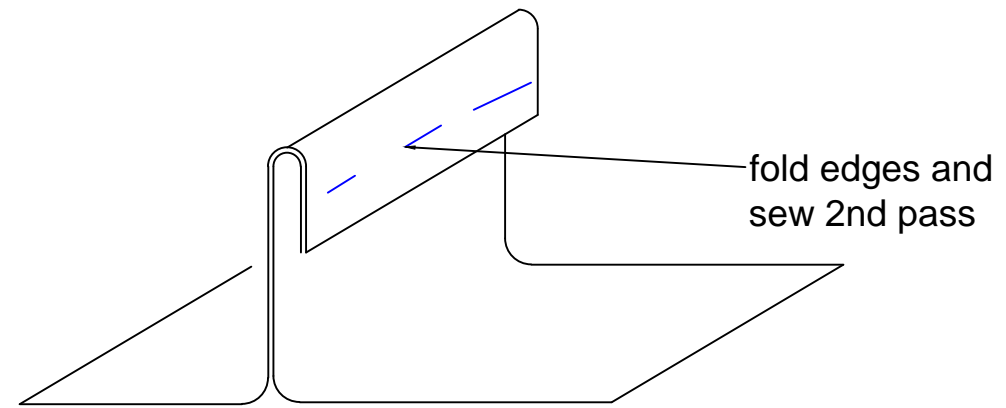
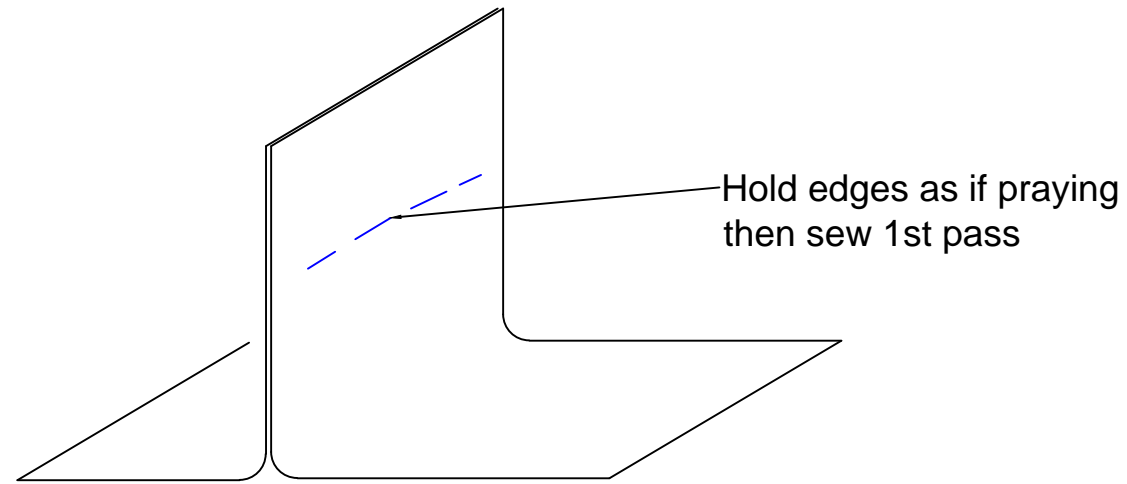

**GENERAL SEWING INSTRUCTIONS**

1. WHEN SEWING MAKE ABOUT A 15 FOOT PASS THEN PULL OUT AND RESTART SEWING ABOUT 3" BEHIND WHERE YOU PULLED OUT. THIS WILL LIMIT THE AMOUNT OF SEWING THAT CAN COME LOOSE FROM A POOR SEAM. DO THIS OVER THE ENTIRE LENGTH TO BE SEWN.
2. FOLD THE SEAM OVER AND REPEAT STEP 1 ACROSS THE ENTIRE LENGTH OF THE SEAM.

		COVER TYPE			
		GENERAL SEWING INSTRUCTIONS Page 3 of 3			
RAVEN ENGINEERED FILMS PO BOX 5107 SIOUX FALLS, SD 57117-5107 +1 (800) 635-3456		SIZE	SALES ORDER	DRAWING NUMBER	REV
DRAWN	RWW	DATE	1/18/2016	B	'
DO NOT SCALE DRAWING		PROPRIETARY AND CONFIDENTIAL INFORMATION OF RAVEN INDUSTRIES INC. THIS DRAWING AND THE INFORMATION HEREON ARE RAVEN INDUSTRIES INC. PROPERTY AND MAY BE USED BY OTHERS ONLY AS AUTHORIZED IN WRITING BY RAVEN INDUSTRIES INC. - ALL RIGHTS RESERVED UNDER THE COPYRIGHT LAWS.			

8

7

6

5

4

3

2

1