

REVISIONS					
LTR	ECO	DESCRIPTION	DATE	APPROVED	ZONE
A		INITIAL_RELEASE	1/22/2016	RWW	
B		REV_TITLE_BLOCK_ADDED_PULL_DIRECTION	3/28/2016	RWW	

NOTES:
1. XXXXX

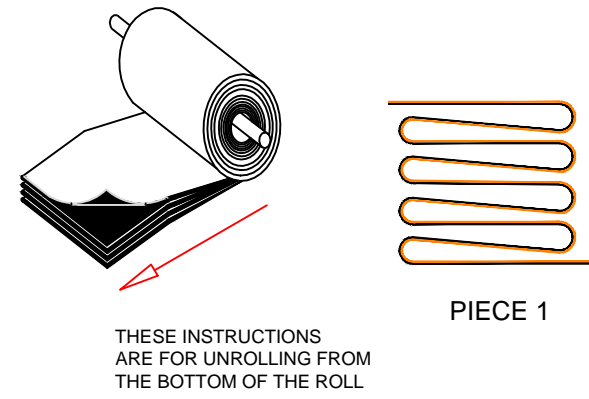

PIECE 1

THESE INSTRUCTIONS ARE FOR UNROLLING FROM THE BOTTOM OF THE ROLL

← UNFOLD

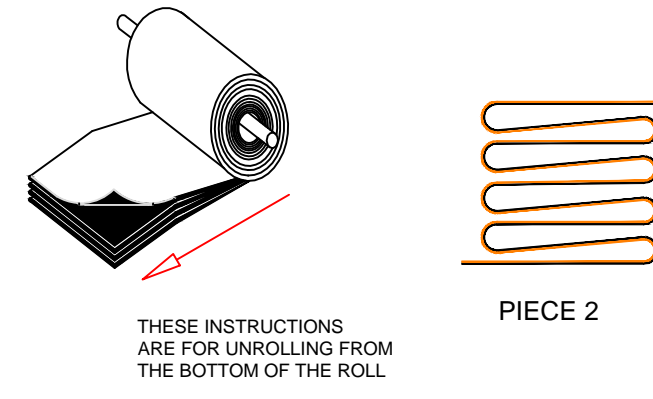
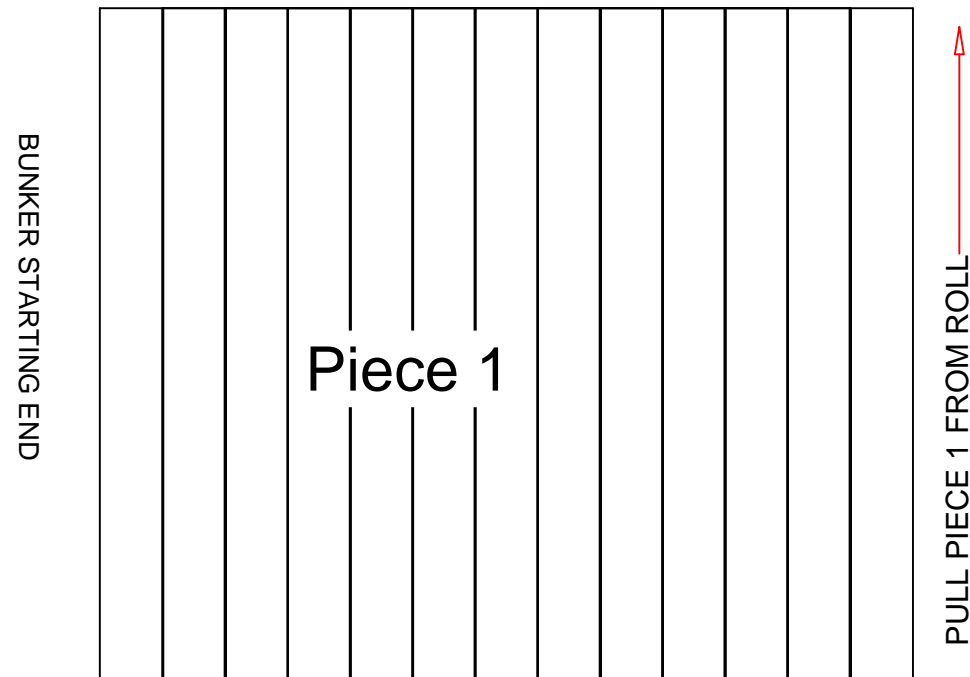

PIECE 2

THESE INSTRUCTIONS ARE FOR UNROLLING FROM THE BOTTOM OF THE ROLL

UNFOLD →

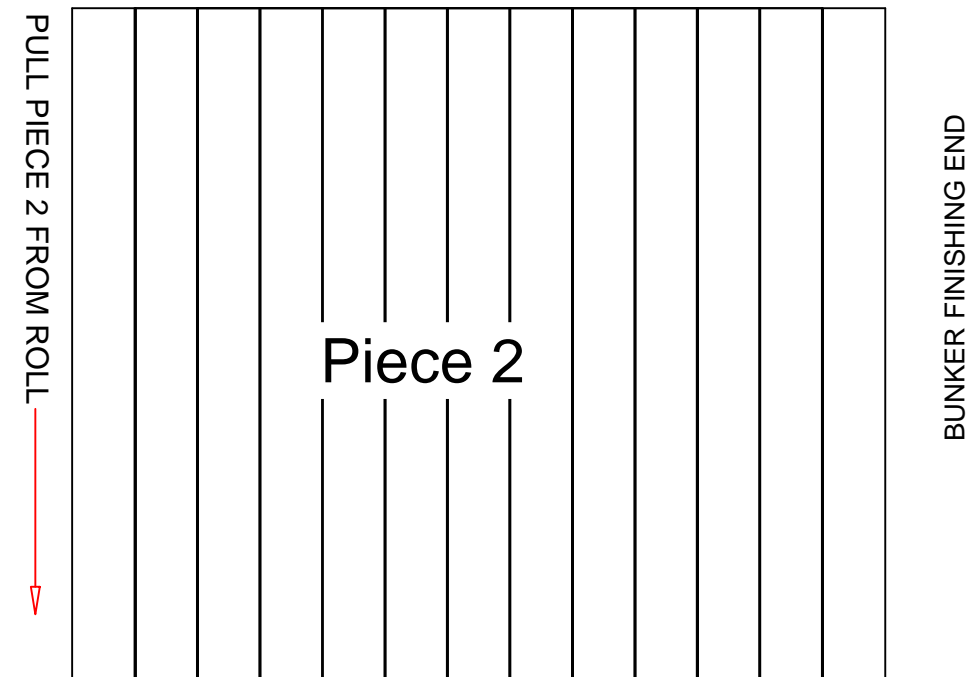

DEPLOYMENT INSTRUCTIONS;

1. PULL PIECE 1 & 2 ACROSS THE GRAIN PILE ABOUT 1/2 OF THE WAY FROM THE STARTING END
 2. SEW PANELS AS SHOWN ON THE GENERAL SEWING INSTRUCTIONS, (PAGE 2 and 3)
 3. WHILE HOLDING PIECE 2, UNFOLD PIECE 1 TO THE STARING END OF THE BUNKER
 4. UNFOLD PIECE 2 TO THE FINISHING END OF THE BUNKER
- FOR FURTHER INSTRUCTIONS VISIT ravenefd.com/installation

RAVEN

RAVEN ENGINEERED FILMS
PO BOX 5107
SIOUX FALLS, SD 57117-5107
+1 (800) 635-3456

NAME: RWW DATE: 1/15/2016

DRAWN: RWW

DO NOT SCALE DRAWING

COVER TYPE
OVAL 2 PIECE, Accordion Fold No Options
Page 1 of 3

SIZE: B	SALES ORDER: 1	DRAWING NUMBER: O2NOAS	REV: B
----------------	-----------------------	-------------------------------	---------------

PROPRIETARY AND CONFIDENTIAL INFORMATION OF RAVEN INDUSTRIES INC.
THIS DRAWING AND THE INFORMATION HEREON ARE RAVEN INDUSTRIES INC. PROPERTY AND MAY BE USED BY OTHERS ONLY AS AUTHORIZED IN WRITING BY RAVEN INDUSTRIES INC.
- ALL RIGHTS RESERVED UNDER THE COPYRIGHT LAWS.

8 7 6 5 4 3 2 1

REVISIONS					
LTR	ECO	DESCRIPTION	DATE	APPROVED	ZONE
A		INITIAL_RELEASE	1/22/2016	RWW	
B		REV_TITLE_BLOCK	3/28/2016	RWW	

NOTES:
XXXXX

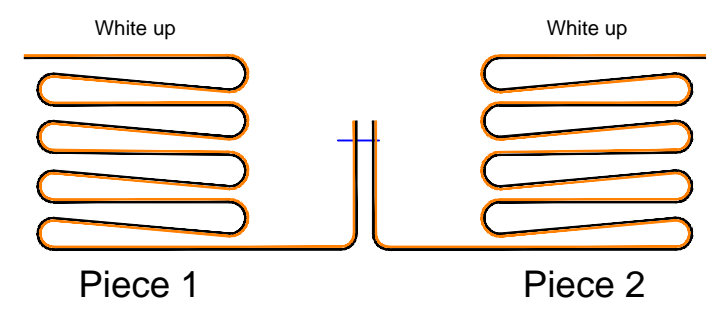

FIGURE 1

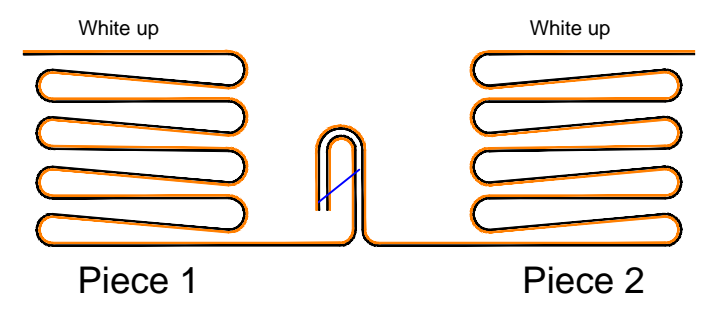

FIGURE 2

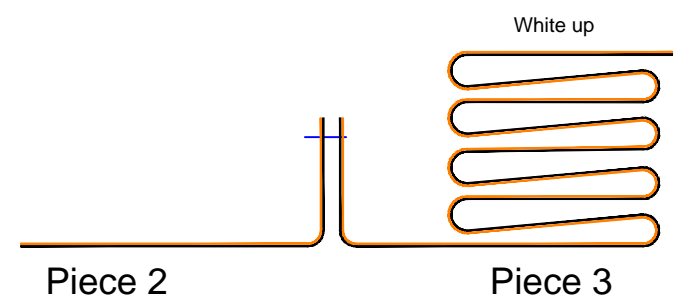

FIGURE 3

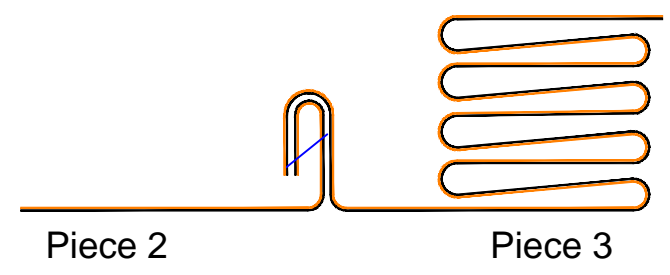

FIGURE 4

- SEWING INSTRUCTIONS**
1. ONCE FIRST AND SECOND PIECE ARE UNROLLED, BRING THE BOTTOM OF BOTH PIECES TOGETHER BLACK TO BLACK, (FIGURE1)
 2. SEW ACROSS THE ENTIRE SEAM AS SHOWN IN THE GENERAL SEWING INSTRUCTIONS, (PAGE 3)
 3. FOLD THE SEAM OVER AND SEW THE ENTIRE SEAM AS SHOWN IN THE GENERAL INSTRUCTIONS, (FIGURE 2)
 4. ONCE PIECE 3 IS UNROLLED, BRING THE BOTTOM OF BOTH PIECES TOGETHER BLACK TO BLACK, (FIGURE 3)
 5. SEW ACROSS THE ENTIRE SEAM AS SHOWN IN THE GENERAL SEWING INSTRUCTIONS, (PAGE 3)
 6. FOLD THE SEAM OVER AND SEW THE ENTIRE SEAM AS SHOWN IN THE GENERAL INSTRUCTIONS, (FIGURE 4)
FOR FURTHER INSTRUCTIONS VISIT ravenefd.com/installation

	COVER TYPE		
	OVAL 3 PIECE, Accordion Folded No Options Page 2 of 3		
RAVEN ENGINEERED FILMS PO BOX 5107 SIOUX FALLS, SD 57117-5107 +1 (800) 635-3456	SIZE	SALES ORDER	DRAWING NUMBER
NAME: RWW DATE: 1/18/2016	B	1	O2NOAS
DO NOT SCALE DRAWING	PROPRIETARY AND CONFIDENTIAL INFORMATION OF RAVEN INDUSTRIES INC. THIS DRAWING AND THE INFORMATION HEREON ARE RAVEN INDUSTRIES INC. PROPERTY AND MAY BE USED BY OTHERS ONLY AS AUTHORIZED IN WRITING BY RAVEN INDUSTRIES INC. - ALL RIGHTS RESERVED UNDER THE COPYRIGHT LAWS.		

8 7 6 5 4 3 2 1

8

7

6

5

4

3

2

1

REVISIONS					
LTR	ECO	DESCRIPTION	DATE	APPROVED	ZONE
A		INITIAL_RELEASE	1/18/2016	RWW	
B		REV_TITLE_BLOCK	3/28/2016	RWW	

NOTES:

XXXXX

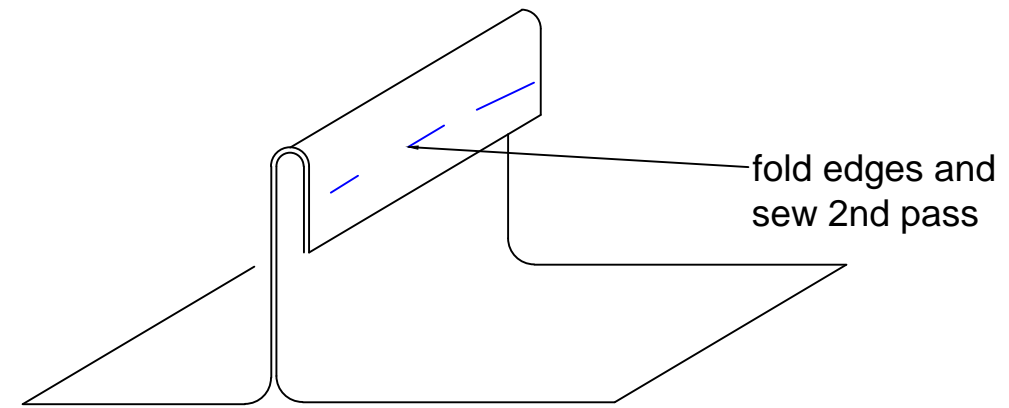
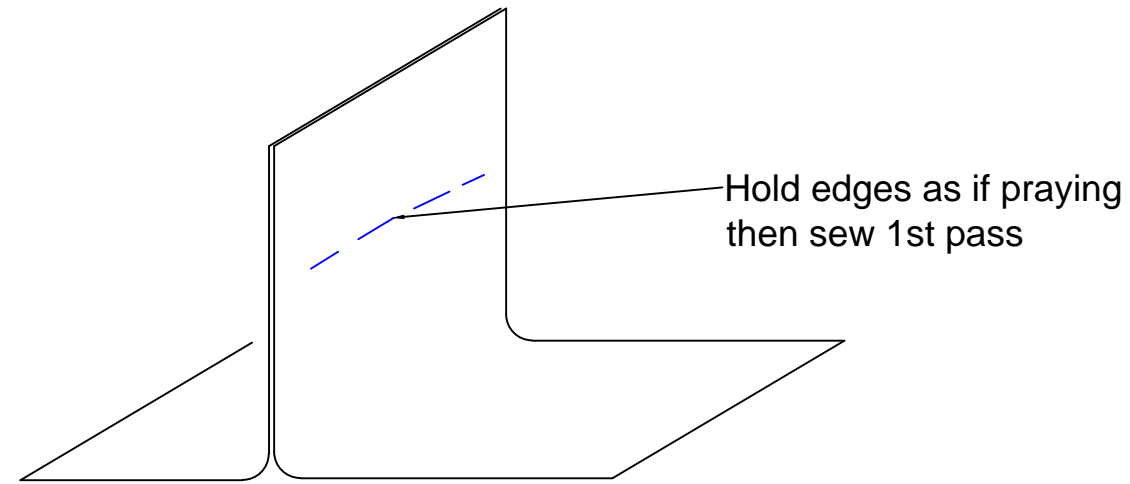

GENERAL SEWING INSTRUCTIONS

1. WHEN SEWING MAKE ABOUT A 15 FOOT PASS THEN PULL OUT AND RESTART SEWING ABOUT 3" BEHIND WHERE YOU PULLED OUT. THIS WILL LIMIT THE AMOUNT OF SEWING THAT CAN COME LOOSE FROM A POOR SEAM. DO THIS OVER THE ENTIRE LENGTH TO BE SEWN.
2. FOLD THE SEAM OVER AND REPEAT STEP 1 ACROSS THE ENTIRE LENGTH OF THE SEAM.

		COVER TYPE			
		GENERAL SEWING INSTRUCTIONS Page 3 of 3			
RAVEN ENGINEERED FILMS PO BOX 5107 SIOUX FALLS, SD 57117-5107 +1 (800) 635-3456		SIZE	SALES ORDER	DRAWING NUMBER	REV
DRAWN	RWW	DATE	1/18/2016	B	'
DO NOT SCALE DRAWING		PROPRIETARY AND CONFIDENTIAL INFORMATION OF RAVEN INDUSTRIES INC. THIS DRAWING AND THE INFORMATION HEREON ARE RAVEN INDUSTRIES INC. PROPERTY AND MAY BE USED BY OTHERS ONLY AS AUTHORIZED IN WRITING BY RAVEN INDUSTRIES INC. - ALL RIGHTS RESERVED UNDER THE COPYRIGHT LAWS.			

8

7

6

5

4

3

2

1