

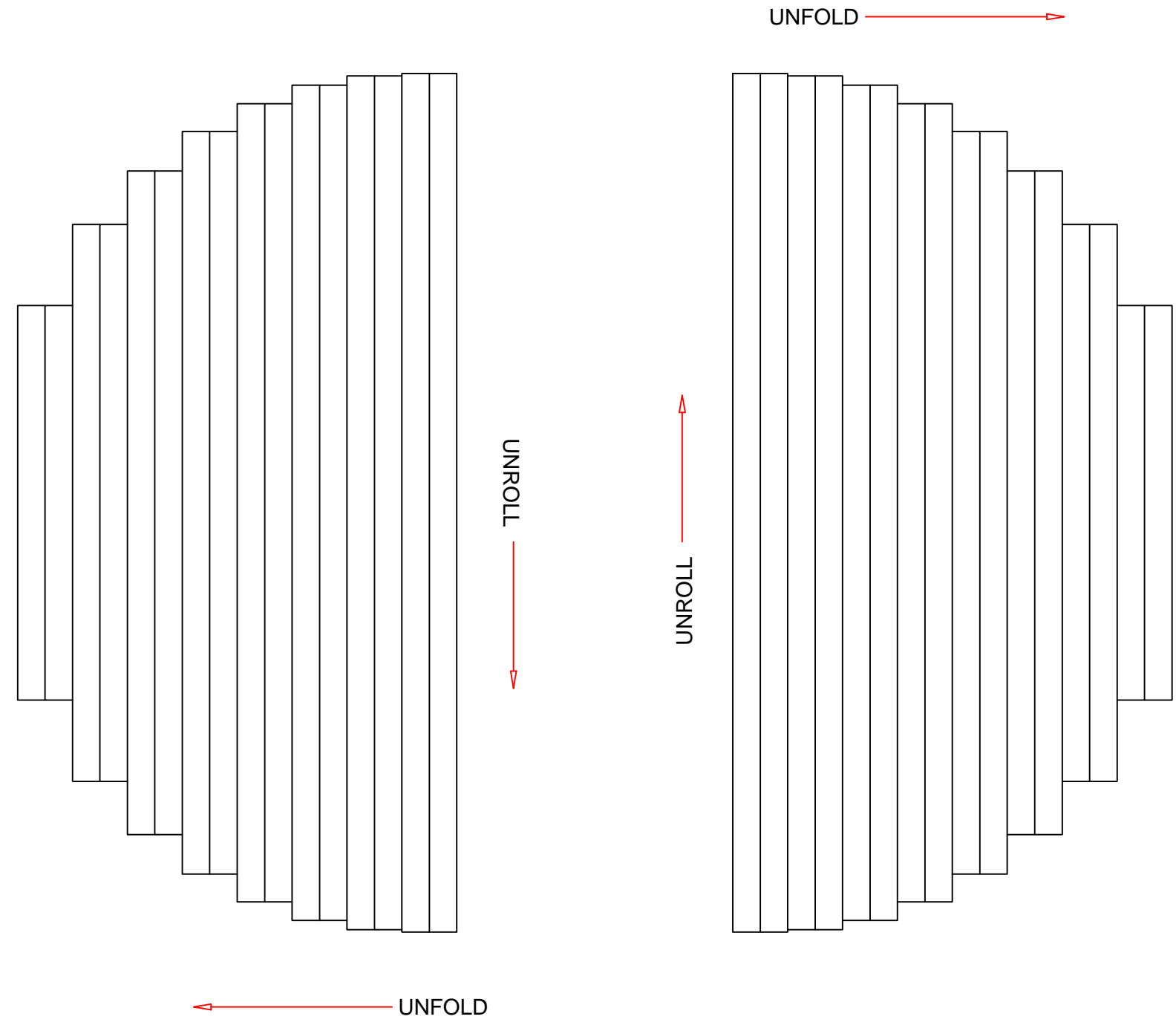

REVISIONS					
LTR.	ECO	DESCRIPTION	DATE	APPROVED	ZONE
A		INITIAL_RELEASE	3/17/2016	RWW	

NOTES:
1. XXXXX



- PLEASE NOTE;
- PULL PIECE 1 AND 2 ACROSS THE GRAIN PILE ABOUT HALF WAY FROM OPPOSITE SIDES OF THE BUNKER.
 - PULL FROM THE TOP OF PIECE 1 TOWARDS THE OUSIDE OF THE BUNKER
 - SEW THE ENTIRE LENGTH OF THE SEAM AS SHOWN ON PAGE 2 AND 3 OF THESE INSTRUCTIONS
 - UNFOLD PIECE 2 TOWARD THE OUTER EDGE OF THE BUNKER
- FOR FURTHER INSTRUCTIONS VISIT ravenefd.com/installation

 RAVEN ENGINEERED FILMS SIOUX FALLS, SD 57117-5107 +1 (605) 635-3456		COVER TYPE		
		CIRCULAR 2 PIECE Accordion Folded Straight Cut		
DRAWN		NAME	DATE	REV
RWW		RWW	4/14/2016	A
DO NOT SCALE DRAWING		PROPRIETARY AND CONFIDENTIAL THE INFORMATION CONTAINED IN THIS DRAWING IS THE SOLE PROPERTY OF RAVEN INDUSTRIES. ANY REPRODUCTION IN PART OR AS A WHOLE WITHOUT THE WRITTEN PERMISSION OF RAVEN INDUSTRIES IS PROHIBITED		

8

7

6

5

4

3

2

1

REVISIONS					
LTR	ECO	DESCRIPTION	DATE	APPROVED	ZONE
A		INITIAL_RELEASE	4/14/2016	RWW	

NOTES:
XXXXX

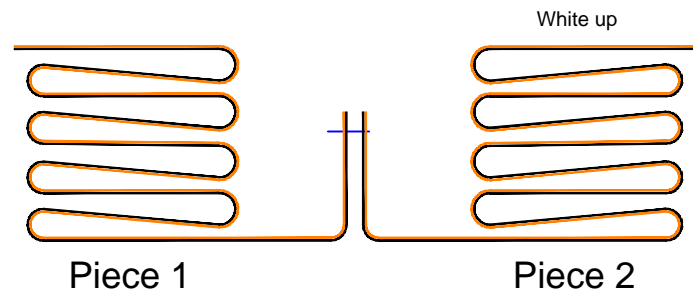

FIGURE 1

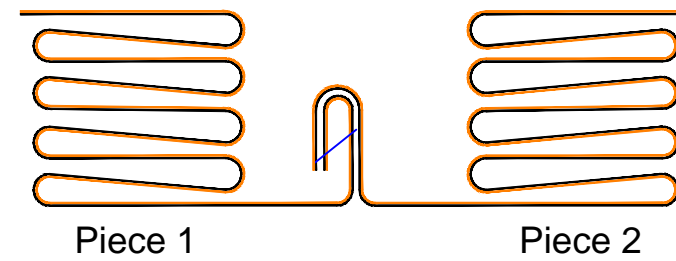

FIGURE 2

SEWING INSTRUCTIONS

1. ONCE FIRST AND SECOND PIECE ARE UNROLLED, BRING THE BOTTOM OF BOTH PIECES TOGETHER BLACK TO BLACK, (FIGURE1)
2. SEW ACROSS THE ENTIRE SEAM AS SHOWN IN THE GENERAL SEWING INSTRUCTIONS, (PAGE 3)
3. FOLD THE SEAM OVER AND SEW THE ENTIRE SEAM AS SHOWN IN THE GENERAL INSTRUCTIONS, (FIGURE 2)

FOR FURTHER INSTRUCTIONS VISIT ravenefd.com/installation

	COVER TYPE			REV
	CIRCULAR 2 PIECE Accordion Folded No Options			
RAVEN ENGINEERED FILMS PO BOX 5107 SIOUX FALLS, SD 57117-5107 +1 (800) 635-3456	SALES ORDER		DRAWING NUMBER	B
NAME: RWW DATE: 4/14/2016	1		C2NOAS-2	
PROPRIETARY AND CONFIDENTIAL INFORMATION OF RAVEN INDUSTRIES INC. THIS DRAWING AND THE INFORMATION HEREON ARE RAVEN INDUSTRIES INC. PROPERTY AND MAY BE USED BY OTHERS ONLY AS AUTHORIZED IN WRITING BY RAVEN INDUSTRIES INC. - ALL RIGHTS RESERVED UNDER THE COPYRIGHT LAWS.				

DO NOT SCALE DRAWING

8

7

6

5

4

3

2

1

8

7

6

5

4

3

2

1

REVISIONS					
LTR	ECO	DESCRIPTION	DATE	APPROVED	ZONE
A		INITIAL_RELEASE	1/18/2016	RWW	
B		REV_TITLE_BLOCK	3/28/2016	RWW	

NOTES:

XXXXX

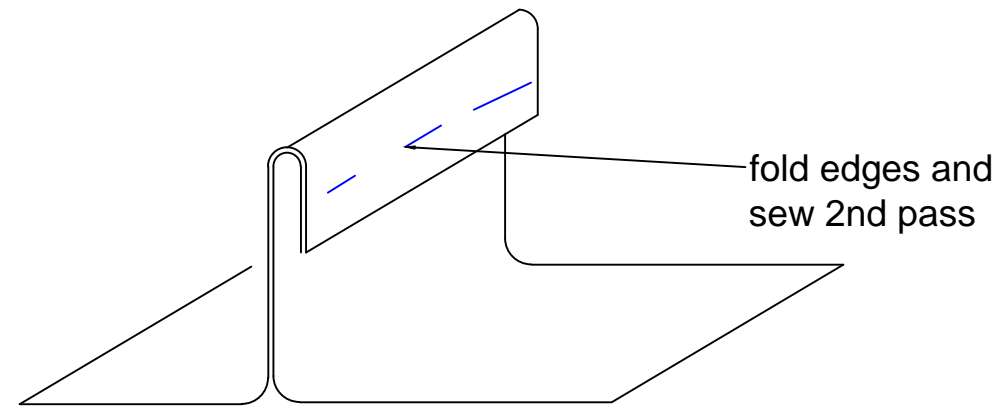
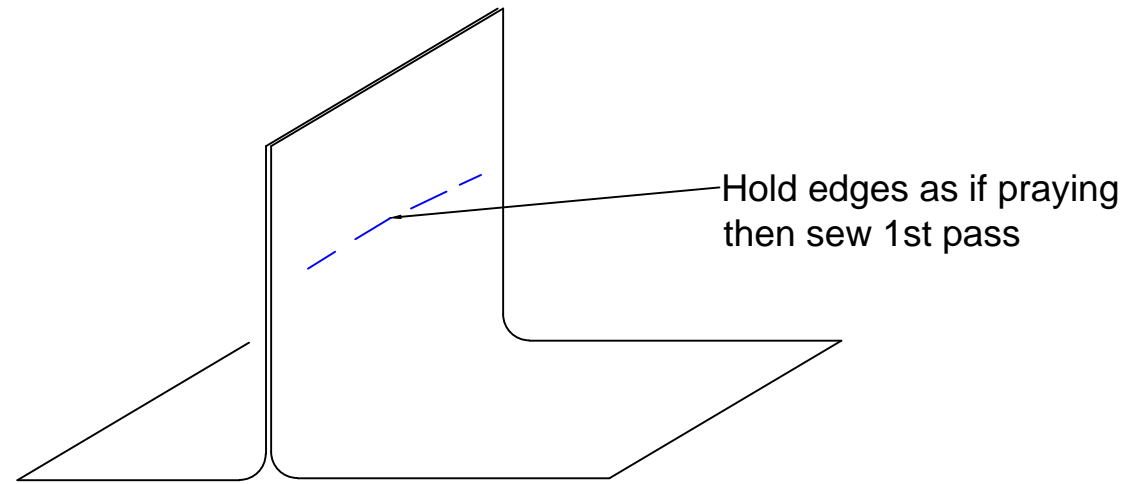

GENERAL SEWING INSTRUCTIONS

1. WHEN SEWING MAKE ABOUT A 15 FOOT PASS THEN PULL OUT AND RESTART SEWING ABOUT 3" BEHIND WHERE YOU PULLED OUT. THIS WILL LIMIT THE AMOUNT OF SEWING THAT CAN COME LOOSE FROM A POOR SEAM. DO THIS OVER THE ENTIRE LENGTH TO BE SEWN.
2. FOLD THE SEAM OVER AND REPEAT STEP 1 ACROSS THE ENTIRE LENGTH OF THE SEAM.

		COVER TYPE			
		GENERAL SEWING INSTRUCTIONS Page 3 of 3			
RAVEN ENGINEERED FILMS PO BOX 5107 SIOUX FALLS, SD 57117-5107 +1 (800) 635-3456		SIZE	SALES ORDER	DRAWING NUMBER	REV
DRAWN	RWW	DATE	1/18/2016	B	'
DO NOT SCALE DRAWING		PROPRIETARY AND CONFIDENTIAL INFORMATION OF RAVEN INDUSTRIES INC. THIS DRAWING AND THE INFORMATION HEREON ARE RAVEN INDUSTRIES INC. PROPERTY AND MAY BE USED BY OTHERS ONLY AS AUTHORIZED IN WRITING BY RAVEN INDUSTRIES INC. - ALL RIGHTS RESERVED UNDER THE COPYRIGHT LAWS.			

8

7

6

5

4

3

2

1