

REVISIONS					
LTR	ECO	DESCRIPTION	DATE	APPROVED	ZONE
A		INITIAL RELEASE	1/20/2016	RWW	
B		REV_TITLE_BLOCK_ADD_UNROLL_DIRECTION	3/30/2016	RWW	

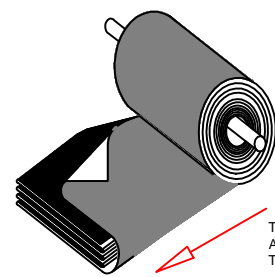

THESE INSTRUCTIONS ARE FOR UNROLLING FROM THE BOTTOM OF THE ROLL

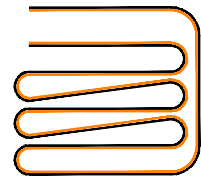
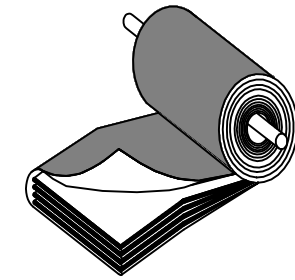
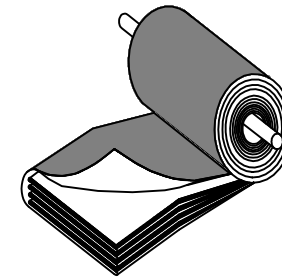
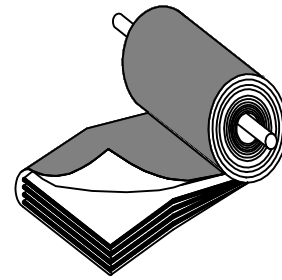
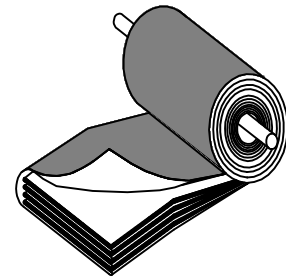

PIECE 1

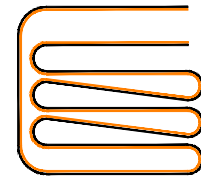

PIECE 2

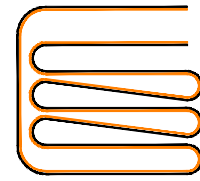

PIECE 3

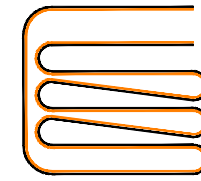

PIECE 4

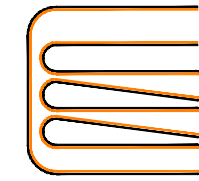

PIECE 5

← UNFOLD

UNFOLD →

UNFOLD →

UNFOLD →

UNFOLD →

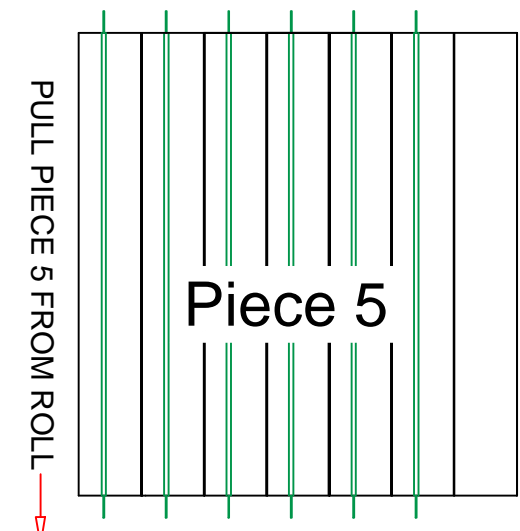
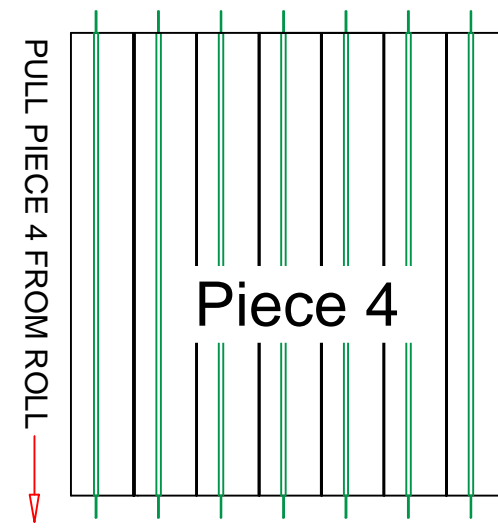
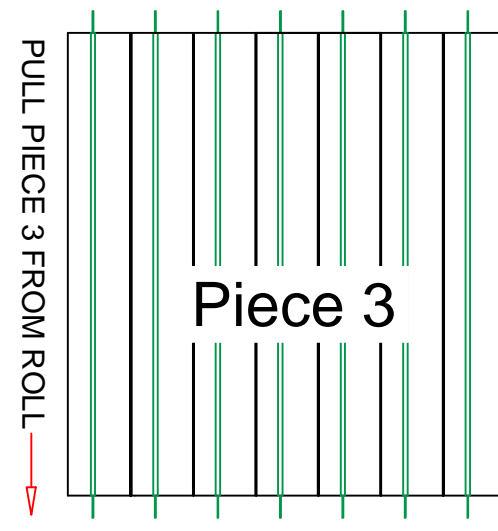
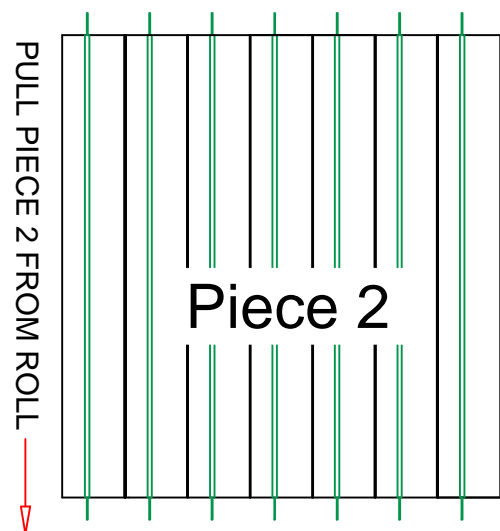
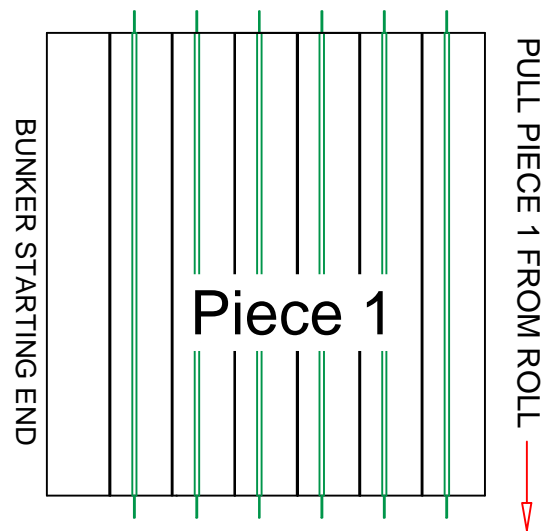

BUNKER STARTING END

BUNKER FINISHING END

DEPLOYMENT INSTRUCTIONS;

1. PULL PIECE 1 & 2 ACROSS THE GRAIN PILE ABOUT 1/4 OF THE WAY FROM THE STARTING END
2. SEW PANELS AS SHOWN ON PAGE 2 AND 3 OF THESE INSTRUCTIONS
3. WHILE HOLDING PIECE 2, UNFOLD PIECE 1 TO THE STARING END OF THE BUNKER
4. UNFOLD PIECE 2
5. UNROLL PIECE 3 ACROSS PILE
6. SEW PIECE 2 AND 3 AS SHOWN ON PAGE 2 AND 3 OF THESE INSTRUCTIONS
7. UNROLL PIECE 4 ACROSS PILE
8. SEW PIECE 3 AND 4 AS SHOWN ON PAGE 2 AND 3 OF THESE INSTRUCTIONS
7. UNFOLD PIECE 4
8. UNROLL PIECE 5 ACROSS PILE
9. SEW PIECE 4 AND 5 AS SHOWN ON PAGE 2 AND 3 OF THESE INSTRUCTIONS
10. UNFOLD PIECE 5 TO THE FINISHING END OF THE BUNKER

FOR FURTHER INSTRUCTIONS VISIT ravenefd.com/installation

		COVER TYPE	
		OVAL 5 PIECE with Straps Flip Fold	
RAVEN ENGINEERED FILMS PO BOX 5107 SIOUX FALLS, SD 57117-5107 +1 (800) 635-3456		SIZE	SALES ORDER
DRAWN: RWW DATE: 1/20/2016		B	1
DO NOT SCALE DRAWING		DRAWING NUMBER	REV
		O5STFS	B
PROPRIETARY AND CONFIDENTIAL INFORMATION OF RAVEN INDUSTRIES INC. THIS DRAWING AND THE INFORMATION HEREON ARE RAVEN INDUSTRIES INC. PROPERTY AND MAY BE USED BY OTHERS ONLY AS AUTHORIZED IN WRITING BY RAVEN INDUSTRIES INC. - ALL RIGHTS RESERVED UNDER THE COPYRIGHT LAWS.			

REVISIONS					
LTR	ECO	DESCRIPTION	DATE	APPROVED	ZONE
A		INITIAL_RELEASE	1/20/2016	RWW	
B		REV_TITLE_BLOCK	3/30/2016	RWW	

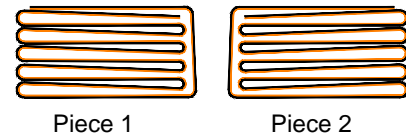

FIGURE 1

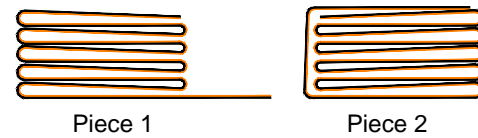

FIGURE 2

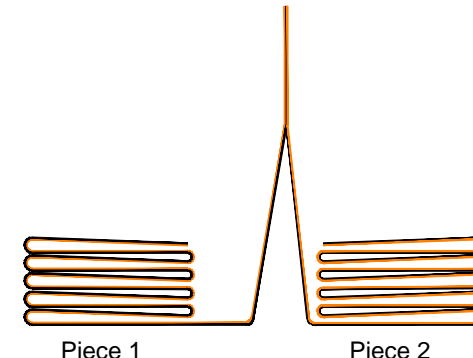

FIGURE 3

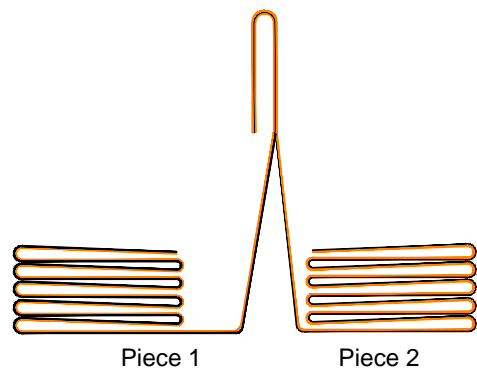

FIGURE 4

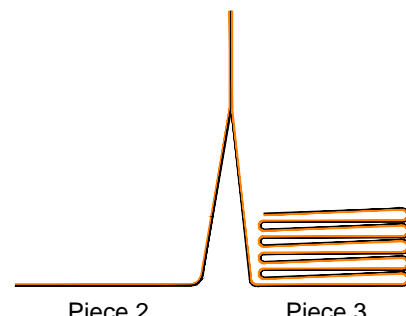

FIGURE 5

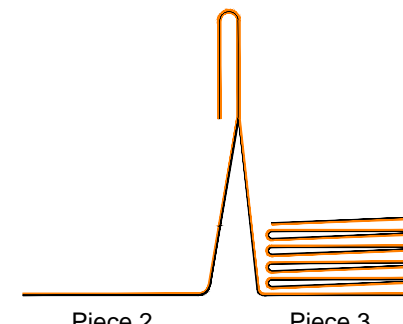

FIGURE 6

SEWING INSTRUCTIONS

1. ONCE FIRST AND SECOND PANEL ARE UNROLLED, FLIP THE TOP FOLD OF PIECE1 TOWARDS PIECE 2, (FIGURE 2)
2. LIFT UP THE FLIP FOLD OF PIECE 1 AND THE TOP PANEL OF PIECE 2 HOLDING THE PANELS TOGETHER BLACK TO BLACK, (FIGURE 3)
3. SEW ACROSS THE ENTIRE SEAM AS SHOWN IN THE GENERAL SEWING INSTRUCTIONS, (PAGE 3)
4. FOLD OVER EXISTING SEWN SEAM AND SEW A SECOND PASS AS SHOWN ON THE GENERAL SEWING INSTRUCTIONS, (FIGURE 4)
5. ONCE PIECE 3 IS UNROLLED LIFT END OF PIECE 2 AND SEW TO FLIP FOLD OF PIECE 3, BLACK TO BLACK, (FIGURE 5)
6. FOLD OVER EXISTING SEWN SEAM AND SEW A SECOND PASS AS SHOWN ON THE GENERAL SEWING INSTRUCTIONS, (FIGURE 6)
7. REPEAT STEPS 5 AND 6 FOR PIECE 4 AND 5
FOR FURTHER INSTRUCTIONS VISIT ravenefd.com/installation

	COVER TYPE		
	OVAL 5 PIECE with Straps Flip Folded		
RAVEN ENGINEERED FILMS PO BOX 5107 SIOUX FALLS, SD 57117-5107 +1 (800) 635-3456	SALES ORDER	DRAWING NUMBER	REV
DRAWN: RWW NAME: RWW DATE: 1/20/2016	B	O5STFS	B
PROPRIETARY AND CONFIDENTIAL INFORMATION OF RAVEN INDUSTRIES INC. THIS DRAWING AND THE INFORMATION HEREON ARE RAVEN INDUSTRIES INC. PROPERTY AND MAY BE USED BY OTHERS ONLY AS AUTHORIZED IN WRITING BY RAVEN INDUSTRIES INC. - ALL RIGHTS RESERVED UNDER THE COPYRIGHT LAWS.			

DO NOT SCALE DRAWING

8

7

6

5

4

3

2

1

REVISIONS					
LTR	ECO	DESCRIPTION	DATE	APPROVED	ZONE
A		INITIAL_RELEASE	1/18/2016	RWW	
B		REV_TITLE_BLOCK	3/28/2016	RWW	

NOTES:

XXXXX

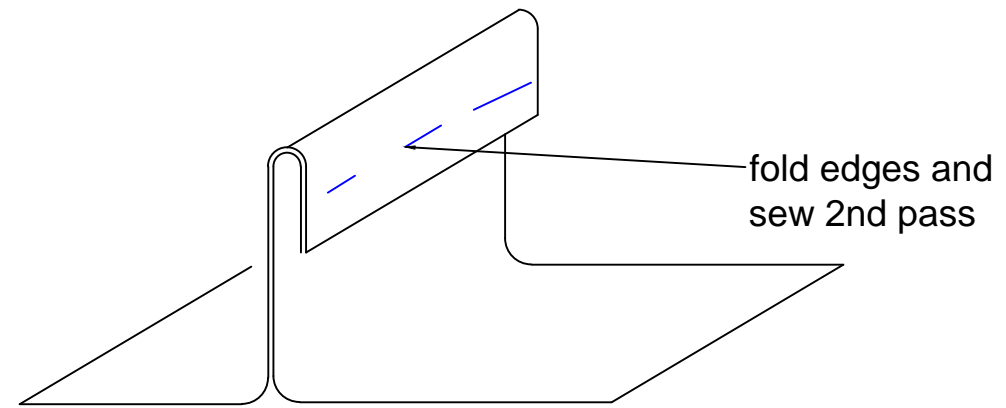
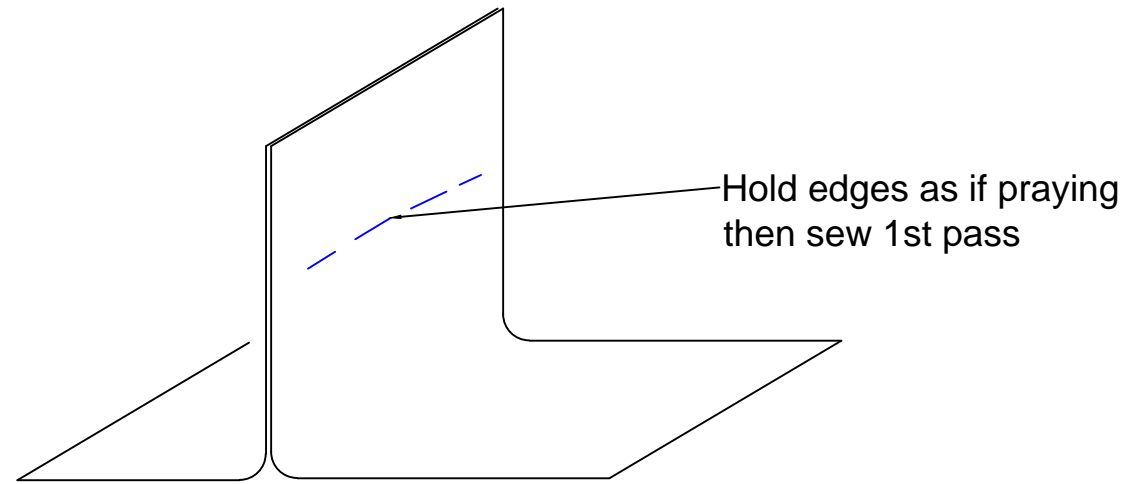

GENERAL SEWING INSTRUCTIONS

1. WHEN SEWING MAKE ABOUT A 15 FOOT PASS THEN PULL OUT AND RESTART SEWING ABOUT 3" BEHIND WHERE YOU PULLED OUT. THIS WILL LIMIT THE AMOUNT OF SEWING THAT CAN COME LOOSE FROM A POOR SEAM. DO THIS OVER THE ENTIRE LENGTH TO BE SEWN.
2. FOLD THE SEAM OVER AND REPEAT STEP 1 ACROSS THE ENTIRE LENGTH OF THE SEAM.

 RAVEN ENGINEERED FILMS PO BOX 5107 SIOUX FALLS, SD 57117-5107 +1 (800) 635-3456	COVER TYPE			REV							
	GENERAL SEWING INSTRUCTIONS Page 3 of 3										
<table border="1"> <tr> <td>NAME</td> <td>DATE</td> <td>SALES ORDER</td> <td>DRAWING NUMBER</td> </tr> <tr> <td>RWW</td> <td>1/18/2016</td> <td>'</td> <td>PAGE_3_OF_3</td> </tr> </table>	NAME	DATE	SALES ORDER	DRAWING NUMBER	RWW	1/18/2016	'	PAGE_3_OF_3	SIZE	B	
NAME	DATE	SALES ORDER	DRAWING NUMBER								
RWW	1/18/2016	'	PAGE_3_OF_3								
PROPRIETARY AND CONFIDENTIAL INFORMATION OF RAVEN INDUSTRIES INC. THIS DRAWING AND THE INFORMATION HEREON ARE RAVEN INDUSTRIES INC. PROPERTY AND MAY BE USED BY OTHERS ONLY AS AUTHORIZED IN WRITING BY RAVEN INDUSTRIES INC. - ALL RIGHTS RESERVED UNDER THE COPYRIGHT LAWS.											

DO NOT SCALE DRAWING

8

7

6

5

4

3

2

1